

Grid:
 ≥ 2,54 mm
 ≥ 100 Mil

Installation height with KS: 8,7 mm (.343)
Recommended stroke: 3,5 mm (.138)

Mounting and functional dimensions

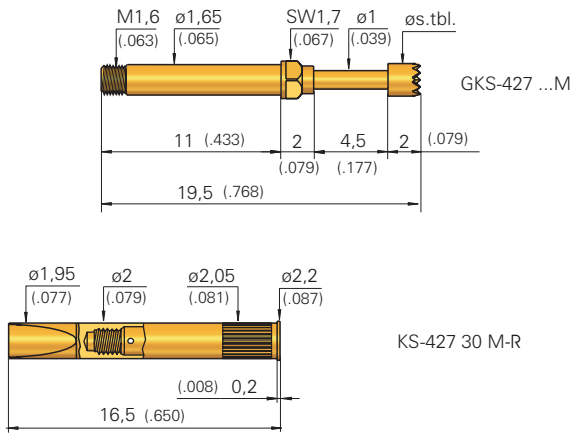

Available tip styles				
Material	Tip style	Plating	Further versions	
			ϕ	ϕ (inch)
2	01	A	$\phi 1,00$ (.039)	
NEW	3	03	$\phi 2,00$ (.079)	
NEW	3	05	$\phi 0,64$ (.025)	0,80 A
NEW	3	05	$\phi 1,00$ (.039)	
3	06	A	$\phi 2,00$ (.079)	1,30 A
NEW	3	13	$\phi 1,00$ (.039)	
NEW	3	17	$\phi 2,00$ (.079)	

Mechanical data

Working stroke: 3,5 mm (.138)
Maximum stroke: 4,5 mm (.177)
Spring force at work. stroke: 1,5 N (5.4oz)
Alternative: 0,8 N (7.2oz); 2,5 N (9.0oz)

Materials

Plunger: BeCu or steel, gold-plated
Barrel: Brass, gold-plated
Spring: Stainless steel (*MC) or steel, gold-plated
Receptacle: Brass, gold-plated

Recommended screw-in torque:
 Min.: 3 cNm / Max.: 5 cNm

Electrical data

Current rating: 5 - 8 A
R_i typical: < 20 m Ω

Mounting hole size

for KS-427 30 M-R ϕ 2,00 - 2,02 mm
in CEM1 and FR4: (.0787 - .0795)

Operating temperature

Standard: -40° up to +80° C
*** with special designation "MC":**
 -100° up to +200° C
 1,5 N (5.4oz); 2,5 N (9.0oz)

Ordering example

	Series	Tip material 2 = Steel 3 = BeCu	Tip style	Tip diameter (1/100 mm)	Plating A = Gold	Spring force (dN)	Collar height (mm)	Type alternative "MC"
Test probe:	G K S	4	2 7	3 0 6	2 0 0	A	1 5	0 2 M
Receptacle:	K S - 4 2 7 3 0 M - R							