

## Product Information

ingun Prüfmittelbau GmbH  
 Max-Stromeyer-Straße 162  
 78467 Konstanz  
 Germany

Tel. +49 7531 8105-0  
 Fax +49 7531 8105-65  
 info@ingun.com  
 www.ingun.com

## Start-up Kit MA 160

For self-customizing of the Manual Test Fixture MA 160 INGUN offers the MA 160 Starter Kit. This Starter Kit contains all the commonly used customizing materials – from the simple Pre-centering Pin through to the Test Probes.

The recommended maximum contacting force lies by 100 N. This allows customizing with 50 spring-loaded Test Probes each with 2 N spring-force.

**Part No. 29070 Start-up Kit MA 160**

The Starter Kit for the Manual Test Fixture MA 160 contains:

MA 160 Start-up Kit (Piece)	Description	
10	Cap for Push-rods Ø 2.5 mm	(22661)
10	Rounded head Screw M3x10	(2962)
10	Washer DIN 9021-3.4	(9286)
4	Placement guide Ø 10 mm	(21628)
4	Countersunk Screw with Allen screw recess M4x10	(3693)
10	PCB Support Pin Ø 5.0 mm, anti-static	(3161)
2	Tooling Pin Ø 2.9 mm	(3175)
2	Tooling Pin Ø 4.0 mm	(3186)
50	Receptacle	(KS-100 30 05)
25	Spring Loaded Test Probe	(GKS-100 291 090 A 2000)
25	Spring Loaded Test Probe	(GKS-100 214 150 A 2000)



Start-up Kit for MA 160

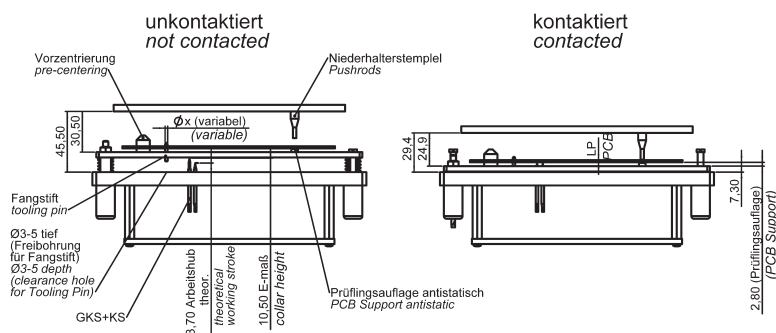

Prices and Delivery Time on request.  
 Technical changes possible without prior notice.